

■ Proportional Electro-Hydraulic Pilot Relief Valves

This valve consists of a small DC solenoid and a direct-acting relief valve. It serves as a pilot valve for a low flow rate hydraulic system or a proportional electro-hydraulic control valve and controls the pressure in proportion to the input current. Note that this valve is used in conjunction with the applicable power amplifier.

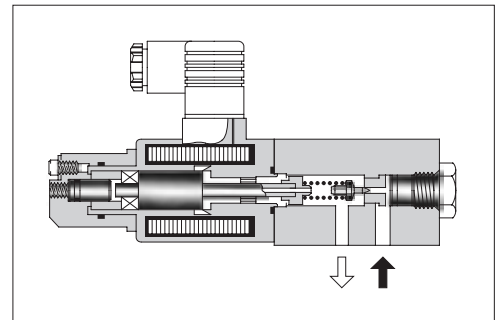

■ Specifications

Model Numbers	EDG-01
Description	EDG-01
Max. Operating Pres.	24.5 MPa (3550 PSI)
Max. Flow	2 L/min (.53 U.S.GPM)
Min. Flow	0.3 L/min (.08 U.S.GPM)
Pressure Adj. Range MPa (PSI)	Refer to Model Number Designation
Rated Current	EDG-01 *-B: 800 mA EDG-01 *-C: 900 mA EDG-01 *-H: 950 mA
Coil Resistance	10 Ω
Hysteresis	3% or less
Repeatability	1% or less
Approx. Mass	2 kg (4.4 lbs.)

Graphic Symbols

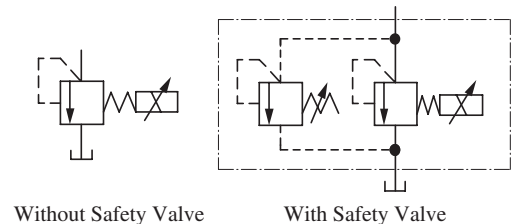

■ Model Number Designation

F-	ED	G	-01	V	-C	-1	-PN	T13	-51	*
Special Seals	Series Number	Type of Mounting	Valve Size	Applicable Control ^{★1}	Pressure Adj. Range MPa (PSI)	Safety Valve	P-Line Orifice	T-Line ^{★2} Orifice	Design Number	Design Standards
F: Special Seals for Phosphate Ester Type Fluid (Omit if not required)	ED: Proportional Electro-Hydraulic Pilot Relief Valve	G: Sub-plate Mounting	01	None: General use	B: 0.5 - 6.9 (70 - 1000)	None: Without Safety Valve 1: With Safety Valve	PN: Without Orifice (Standard)	T15	51	Refer to ^{★3}
				V: Vent Control of Relief Valve (Omit if not required)	C: 1.0 - 15.7 (145 - 2275)			T13		
					H: 1.2 - 24.5 (175 - 3550)			T11		

★1. When the valve is to be used for vent control purpose, orifice adjustment is required due to piping capacity limitations. Therefore, consult your Yuken representative in advance.

★2. The orifice used as the pilot valve may differ from the standard orifice.

★3. Design Standards: None Japanese Standard "JIS" and European Design Standard 90 N. American Design Standard

Attachment

Mounting Bolts

Four socket head cap screws in the table below are included.

Descriptions	Soc. Hd. Cap Screw
Japanese Standard "JIS" European Design Standard	M5 × 45 Lg.
N. American Design Standard	No. 10 - 24 UNC × 1-3/4 Lg.

Sub-plate

Piping Size	Japanese Standard "JIS"		European Design Standard		N. American Design Standard		Approx. Mass kg (lbs.)
	Sub-plate Model Numbers	Thread Size	Sub-plate Model Numbers	Thread Size	Sub-plate Model Numbers	Thread Size	
1/8	DSGM-01-31	Rc 1/8	DSGM-01-3180	1/8 BSP.F	DSGM-01-3190	1/8 NPT	0.8 (1.8)
1/4	DSGM-01X-31	Rc 1/4	DSGM-01X-3180	1/4 BSP.F	DSGM-01X-3190	1/4 NPT	0.8 (1.8)
3/8	DSGM-01Y-31	Rc 3/8	—	—	DSGM-01Y-3190	3/8 NPT	0.8 (1.8)

- Sub-plates are available. Specify the sub-plate model number from the table above. When sub-plates are not used, the mounting surface should have a good machined finish.
- Sub-plates are those for 1/8 solenoid operated directional valves. For dimensions, see [page 356](#).

Instructions

Tank-Line Back Pressure

Check that the tank line back pressure does not exceed 0.2 MPa (29 PSI).

Vent Control

When the valve is used for vent control of relief valves or others, use the pipes of 6 mm (.24 in.) ID. 300 mm (11.8 in.) or less length for connection.

If the pressure is instable, provide a 1.0 to 1.5 mm (.04 to .06 in.) diameter orifice to the vent port of the relief valves or others.

Circuit Pressure Control

When the pressure in a circuit is directly controlled with this valve, set the trapped oil volume being more than 40 cm³ (2.44 cu. in.).

Applicable Power Amplifier

For stable performance, it is recommended that Yuken's applicable power amplifiers be used (for details see [page 767, 771, 780](#)).

Model Numbers : AME-D-10-*-20
 AME-D2-1010-11
 SK1022-**-*-11
 SK1015-11 (For DC power supply)
 AMN-D-10 (For DC power supply)

Safety Valve Pressure Setting

The pressure of the safety valve at the maximum flow is preset at the value equal to the upper limit of the pressure adjustment range plus 2 MPa (290 PSI).

In case where the upper limit of operating pressure is low or the upper limit of flow rate to be used is different from the specified maximum flow, please adjust and determine the setting pressure of the safety valve at the value calculated from the following formula.

Setting pressure = (Operating pressure upper limit) + (Additional pressure indicated below)

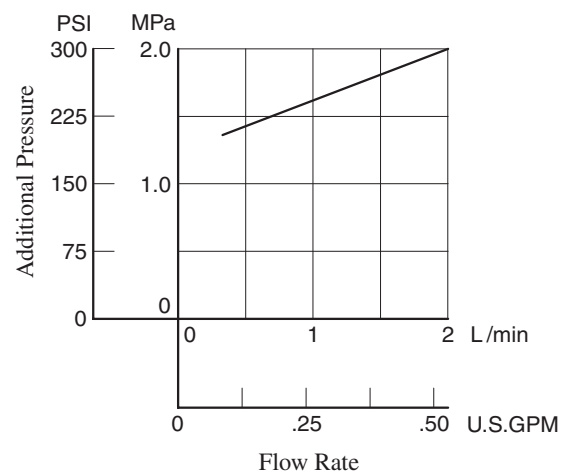

To lower the setting pressure, turn the safety valve pressure adjustment screw anti-clockwise. After adjustment, be sure to tighten the lock nut.

EDG-01*-*-1-PNT*-51/5190

With Safety Valve

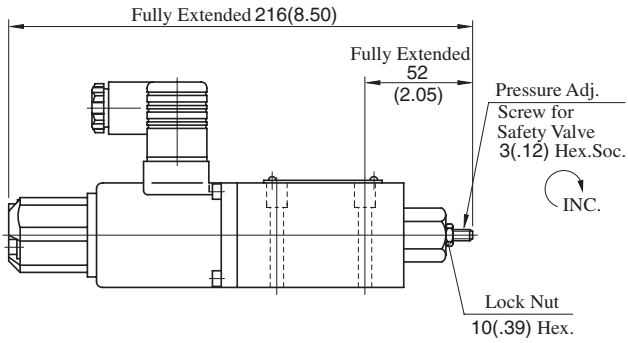

• For other dimensions, refer to the without safety valve.

EDG-01*-*-PNT*-51/5190

Without Safety Valve

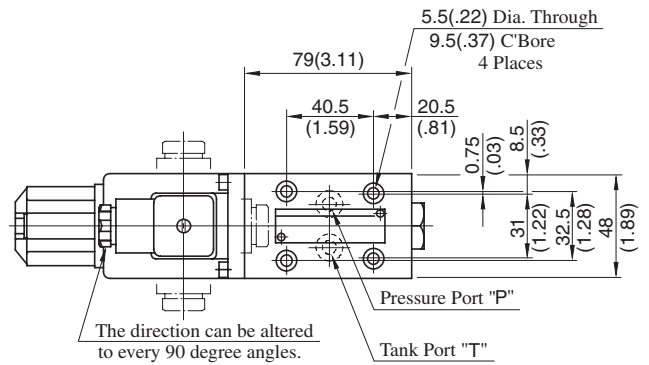

DIMENSIONS IN MILLIMETRES (INCHES)

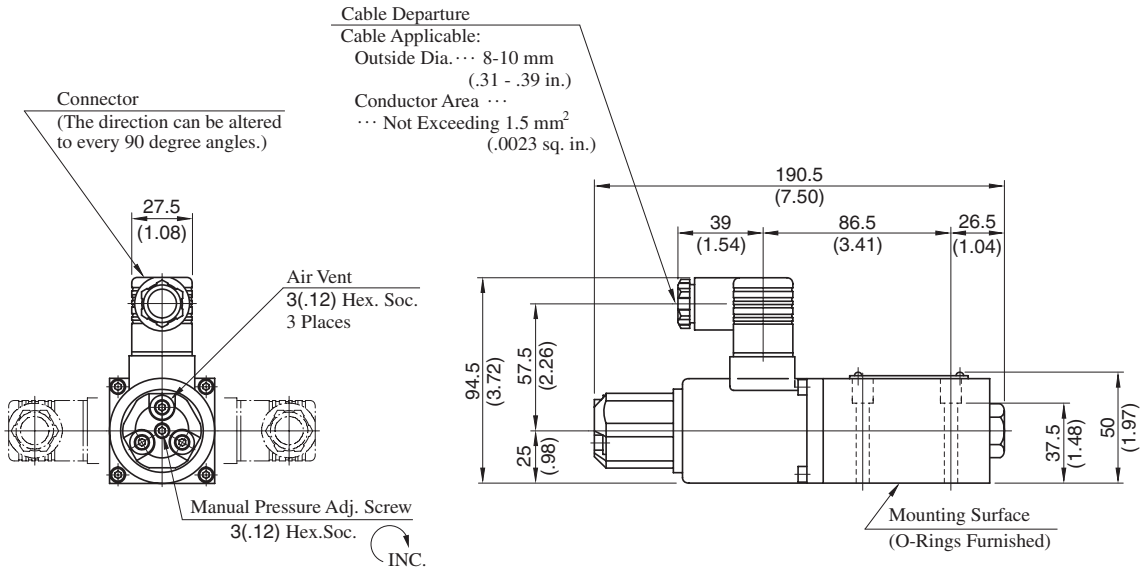

Note: For valve mounting surface dimensions, see the dimensional drawings of sub-plates (P.356) in common use.

Step Response (Example)

These characteristics have been obtained by measuring on each valve. Therefore, they may vary according to a hydraulic circuit to be used.

Flow Rate : 2 L/min (.53 U.S. GPM)
 Trapped Oil Volume : 40 cm³ (2.44 cu. in.)
 Viscosity : 30 mm²/s (141 SSU)

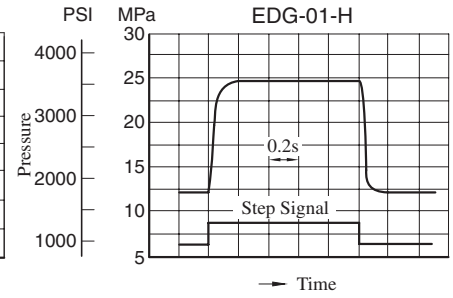
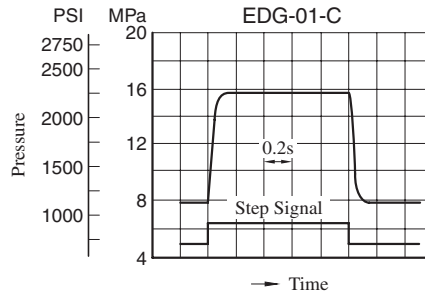
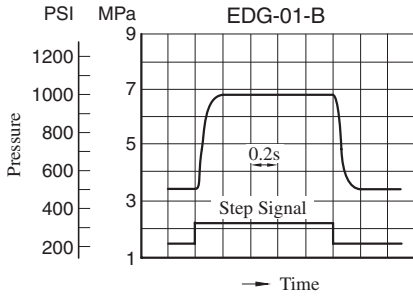

Frequency Response

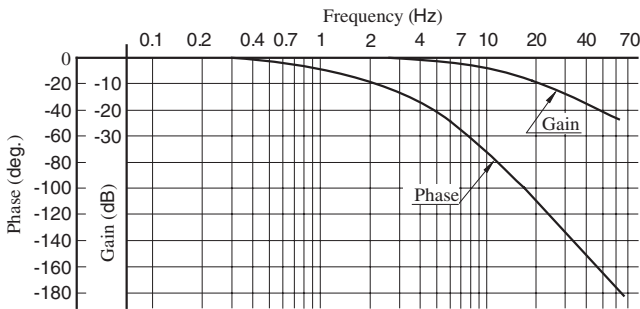

Flow Rate : 2 L/min (.53 U.S. GPM)
 Pressure : 7.8 ± 1.6 MPa (1130 ± 230 PSI)
 Trapped Oil Volume : 30 cm³ (1.83 cu. in.)
 Viscosity : 30 mm²/s (141 SSU)

Control Pressure vs. Input Current

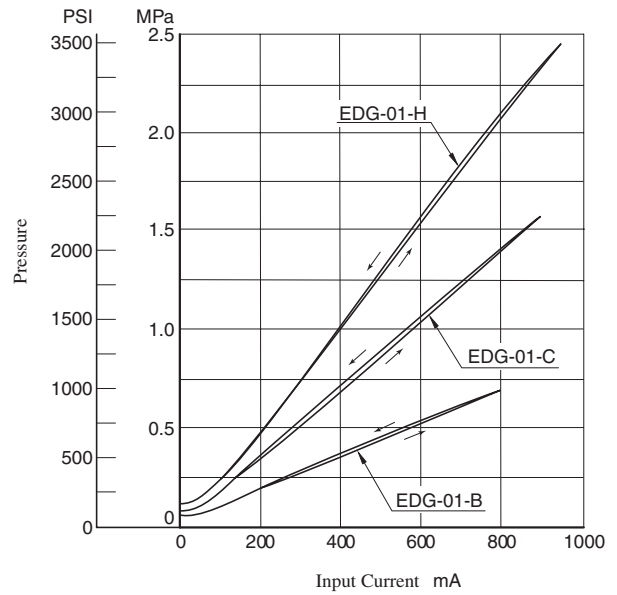

Min. Adjustment Pressure

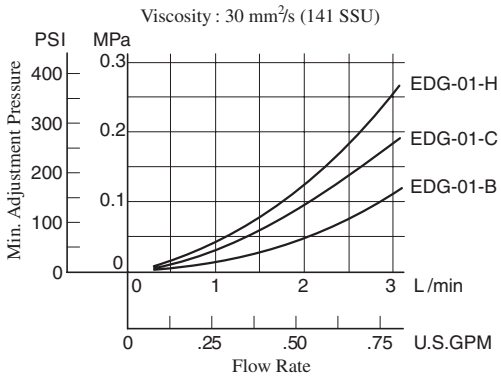

Flow Rate vs. Pressure

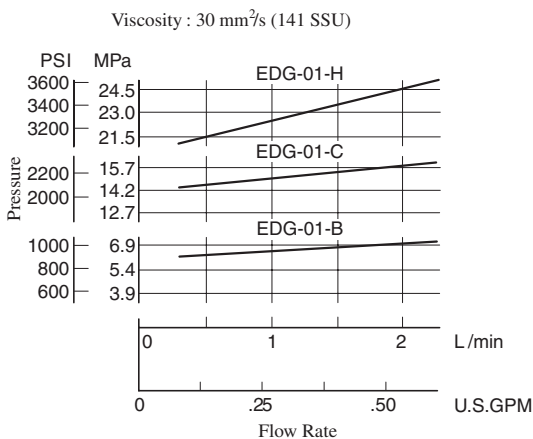

Viscosity vs. Pressure

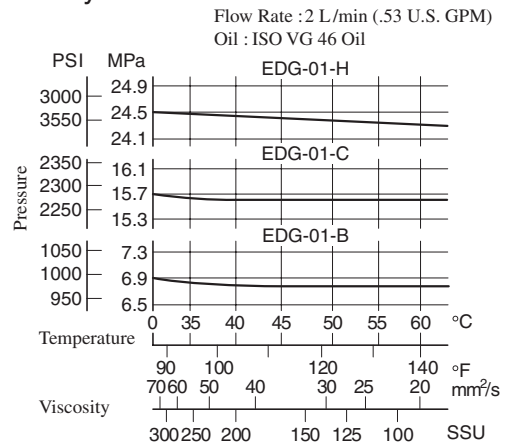

■ List of Seals and Solenoid Ass'y

● Without Safety Valve

EDG-01*-*-PNT*-51/5190

EDG-01V- *-PNT*-5103

EDG-01- *-PNT*-5101

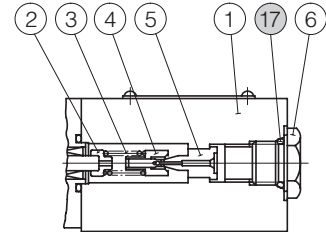
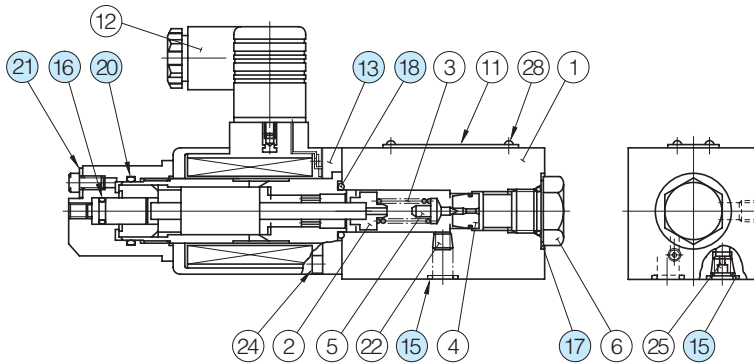

● With Safety Valve

EDG-01*-*-1-PNT*-51/5190

EDG-01V- *-1-P*T*-5103/5197

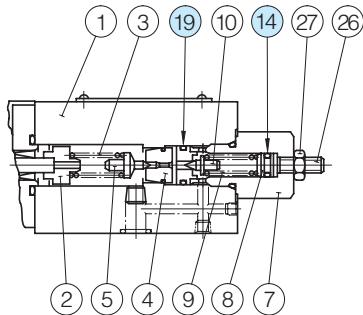

● List of Seals

Item	Name of Parts	Part Numbers	Qty.	Remarks
14	O-Ring	SO-NA-P6	1	Included in Seal Kit Kit No.: KS-EDG-01-51
15	O-Ring	SO-NB-P9	2	
16	O-Ring	SO-NB-P7	1	
17	O-Ring	SO-NB-P14	1	
18	O-Ring	SO-NB-P18	1	
19	O-Ring	SO-NB-A013	1	
20	O-Ring	SO-NB-P22	1	
21	Fastener Seal	SG-FCF-4	1	

Note) O-ring (Item 16, 18, 20) and the fastener seal (Item 21) are included in the solenoid assembly.

● Solenoid Ass'y

Valve Model Numbers	⑬ Solenoid Ass'y
EDG-01- *- *-P*T*-51/5190 EDG-01- *- *-P*T*-5101	E318-Y06M1-28-61
EDG-01V- *- *-P*T*-51/5190	E318-Y06M1-05-61
EDG-01V- *- *-PNT*-5103	E318-Y06M1-04-61
EDG-01V- *-1-PNT20-5197	E318-Y06M1-28-61

Note) The connector assembly GDM-211-B-11 (Item 12) is not included in the solenoid assembly.

Interchangeability between Current and New Design

EDG-01 series valve has changed model from 50 to 51 design in line with the solenoid improvement.

Specifications and Characteristics

No change in specifications and characteristics between current and new design.

Mounting Interchangeability

There is an interchangeability in the mounting dimensions, however, the outside shape and dimensions are changed as shown below due to solenoid improvement and other modifications.

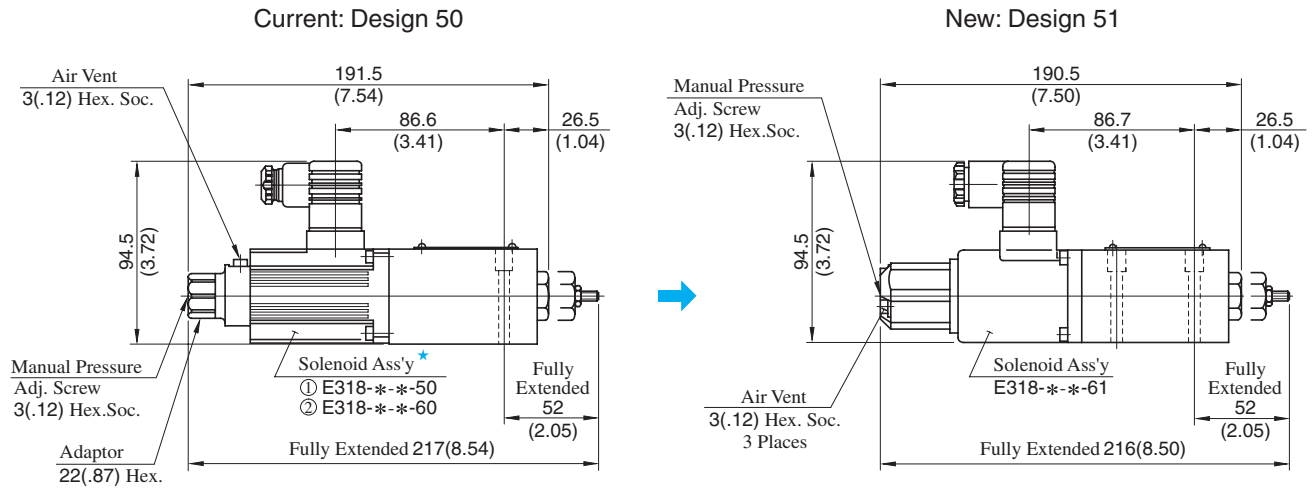

★ The solenoid assembly current design comes in two types: ① E318-50 design and ② 60 design. See the figure on the left for an external view of type ①. See the figure on the right for type ②.

DIMENSIONS IN
MILLIMETRES (INCHES)